

Fire Sentry Battery Operated 4" Smoke Alarm

Model i9040 (formerly Model 0914)



Test Button
Tests unit's electronic circuitry, horn and battery function

Discreet Design
Four (4) inch diameter

**Also available with
5" Mounting Plate (0914E)**
Covers paint rings replacing 5" alarms

Description

The Fire Sentry i9040 smoke alarm is a battery operated smoke alarm that utilizes ionization sensing technology. The four (4) inch unit is smaller in diameter giving it discreet design with the same quality you would expect in a Kidde manufactured product. The i9040 is powered by a 9V battery, providing continuous protection, even during power outages. This easy to install unit includes a test button to verify the detection electronics are working as intended.

Consumer Benefits

The Fire Sentry i9040 battery operated, single station smoke alarm provides an early warning signal to you and your family in the event of a fire hazard. The i9040 operates on a 9V battery power source that provided continuous protection even during a power outage, Installation is easy, no wiring required. This unit is UL Listed and includes a 3 year limited warranty.

Features and Benefits

- **Battery Operated (9V Battery Included)** – Easy installation and provides continuous protection even during power outages.
- **Test Button** – Tests unit's electronic circuitry, horn and battery function.
- **Low Battery Indicator** – Low battery warning chirp alerts user to change battery.
- **Discreet Design** – Four (4) inch diameter.



Architectural and Engineering Specifications

The smoke alarm shall be Kidde Model Number i9040 or approved equal. It shall be powered by a 9V battery. The unit shall incorporate an ionization smoke sensor with nominal sensitivity of 0.52-1.12%/ft. The temperature operating range shall be between 40°F and 100°F (4°C and 38°C) and the humidity operating range shall be up to 85% relative humidity.

The alarm can be installed on the surface of any wall or ceiling following the UL/NFPA/Manufacturer's recommended placement guidelines.

The alarm shall include a test button that will electronically simulate the presence of smoke and cause the unit to go into alarm. This sequence tests the unit's electronics, battery and horn to ensure proper operation.

The unit shall include a piezoelectric horn that is rated at 85 decibels at 10 feet. The alarm shall produce the ANSI S3.41 three pulse temporal pattern audible emergency evacuation signal.

The unit shall also indicate a low battery warning utilizing a brief alarm chirp every 30-40 seconds for a minimum of seven (7) days.

The smoke alarm shall at a minimum meet the requirements of UL 217, NFPA 72, The California State Fire Marshall, NFPA 101 (One and two family dwellings Federal Housing Authority (FHA)). It shall also include a 3-year manufacturer's limited warranty.

Technical Specifications

Model Number:	i9040
Power Source:	9V Battery (included)
Audio Alarm:	85dB at 10ft
Temperature Range:	40°F to 100°F (4°C to 38°C)
Humidity Range:	up to 85% relative humidity (RH)
Sensor:	Ionization
Size:	4" in diameter x 1.45" depth
Weight:	.5lbs
Interconnects:	No
Warranty:	3 year limited

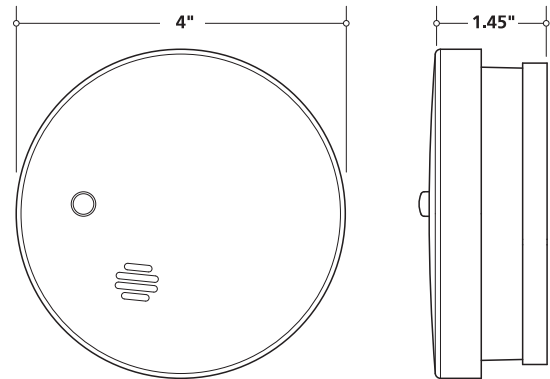

Ordering Information

Includes 9V Carbon Zinc Battery

Ordering Number	UPC	1 of 5	Pack Config.	Pack Quantity	Dimensions (w x d x h inches)	Case Weight	Cases per pallet
0914	0-25417--00914-9	200-25417-00914-3	BOX	Cut Case (12 Units)	6.60 x 13.00 x 4.60	4.55 lbs	168
0914-9960	0-25417--91460-3	200-25417-91460-7	BOX	Cut Case (8 Units)	10.30 x 10.70 x 7.60	7.30 lbs	84
0914-040	0-25417--91422-1	300-25417-91422-2	BOX	Cut Case (40 Units)	9.00 x 17.00 x 9.00	15.00 lbs	30
0914T-020	0-25417--91422-1	200-25417-91422-5	BOX	Cut Case (20 Twin Packs)	9.00 x 17.00 x 9.00	15.00 lbs	60
0914E	0-25417--09145-8	200-25417-09145-2	BOX	Master Pack (12 Units)	10.10 x 10.10 x 5.10	5.20 lbs	112

**Not for sale by individual unit



1016 Corporate Park Drive
Mebane NC 27302
1-800-880-6788
www.kidde.com

Distributed by:

Select Safety Sales LLC
P.O. Box 826, Clark, NJ 07066
TEL (866) 864-3495, FAX (732) 381-4365
www.selectsafetysales.com

